



AIR TORQUE

AIR TORQUE S.p.A.
 via Alla Campagna, N° 1
 24060 Costa di Mezzate (Bg) Italy
 Tel.: +39 035 682299
 Fax: +39 035 687791
 E-mail: info@airtorque.it

T.D.S. n° U00400FE

Issued on: 10/09 - Page 1/1

COATING SPECIFICATION FOR 4thG Upgrade Series PROTECTION LEVEL "F"

RAL 7046



SUITABLE FOR :

- General service
- Acids or basic solutions in low concentration

NOT RECOMMENDED FOR :

- Nitric acid
- N-Methyle Pirolidone (Solvent)

PARTS AND COATING SPECIFICATION

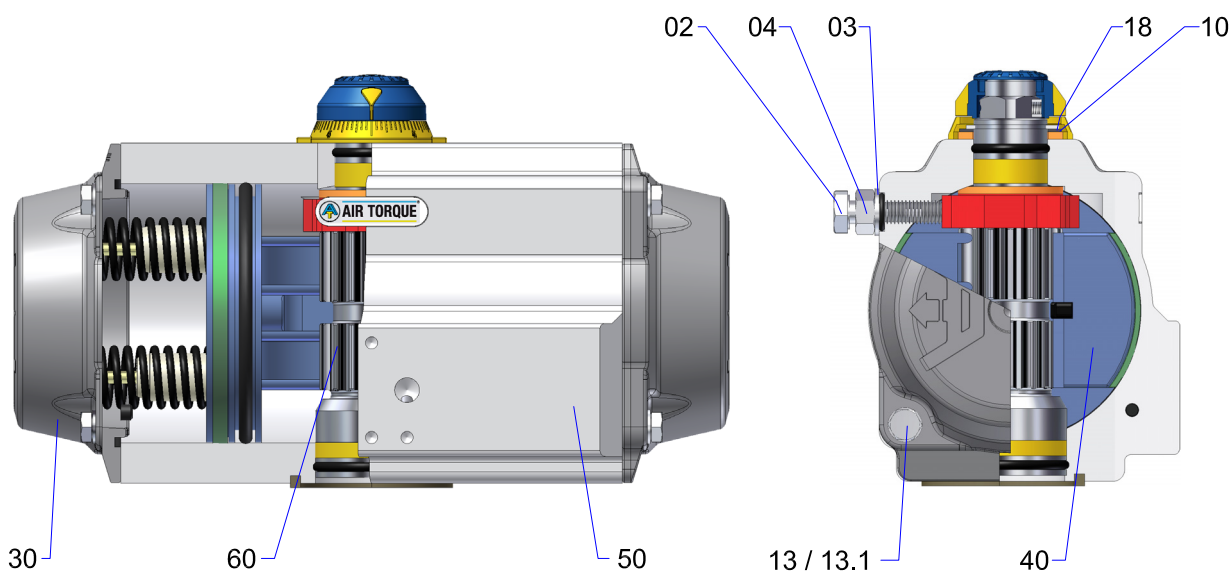

PART N°	UNIT Q.TY / NOTE	PART DESCRIPTION	STANDARD MATERIAL	CORROSION PROTECTION	COATING THICKNESS IN μ	STANDARD COLOUR
02	2 NA for AT045U	STOP CAP SCREW	Stainless Steel A4 70 (ISO 3506)	/	/	/
03	2 NA for AT045U	WASHER	Stainless Steel A4 (ISO 3506)	/	/	/
04	2 NA for AT045U	NUT (Stop screw)	Stainless Steel A4 70 (ISO 3506)	/	/	/
10	1 for AT045U ÷ AT801U	THRUST WASHER (Pinion)	Stainless Steel AISI 304	/	/	/
13	8/12/16 for AT045U ÷ AT801U	CAP SCREW (End cap)	Stainless Steel A4 70 (ISO 3506)	/	/	/
13.1	16 only for AT1001U	WASHER (Cap Screw end cap)	Stainless Steel A4 70 (ISO 3506)	/	/	/
18	1 for AT045U ÷ AT1001U	SPRING CLIP (Pinion)	Stainless Steel AISI 302	/	/	/
30	2 for AT045U ÷ AT801U	END CAP	Pressure Die Cast Aluminium alloy	Anodized + • 1 st C. Primer coating • 2 nd C. Epoxy coating	30 - 40	RAL7046
	only for AT1001U		Cast Aluminium alloy		30 - 40	
40	2 for AT045U ÷ AT801U	PISTON	Pressure Die Cast Aluminium alloy	Anodized	10 - 15	Black
	only for AT1001U		Cast Aluminium alloy			
50	1 for AT045U ÷ AT751U	BODY	Extruded Aluminium alloy	Anodized + • 1 st C. Primer coating • 2 nd C. Epoxy coating	25 5 - 10 40 - 70	RAL7046
	for AT801U and AT1001U		Cast Aluminium alloy		15 - 20 30 - 40 40 - 60	
60	1 for AT045U ÷ AT1001U	DRIVE SHAFT (With Integral Top)	Stainless Steel AISI 316 (1.4401)	E.N.P.	20 - 25	/

Note:

- For all other parts description and material see technical data sheet of the proper model.