



AIR TORQUE

AIR TORQUE S.p.A.
 via Alla Campagna, N° 1
 24060 Costa di Mezzate (Bg) Italy
 Tel.: +39 035 682299
 Fax: +39 035 687791
 E-mail: info@airtorque.it

T.D.S. n° U00400PE

Issued on: 10/09 - Page 1/1

COATING SPECIFICATION FOR 4thG Upgrade Series PROTECTION LEVEL "P"



SUITABLE FOR :

- General service
- Suggested for any kind of solvent

NOT RECOMMENDED FOR :

- Caustic Soda
- All strong Acids or basic solutions

PARTS AND COATING SPECIFICATION

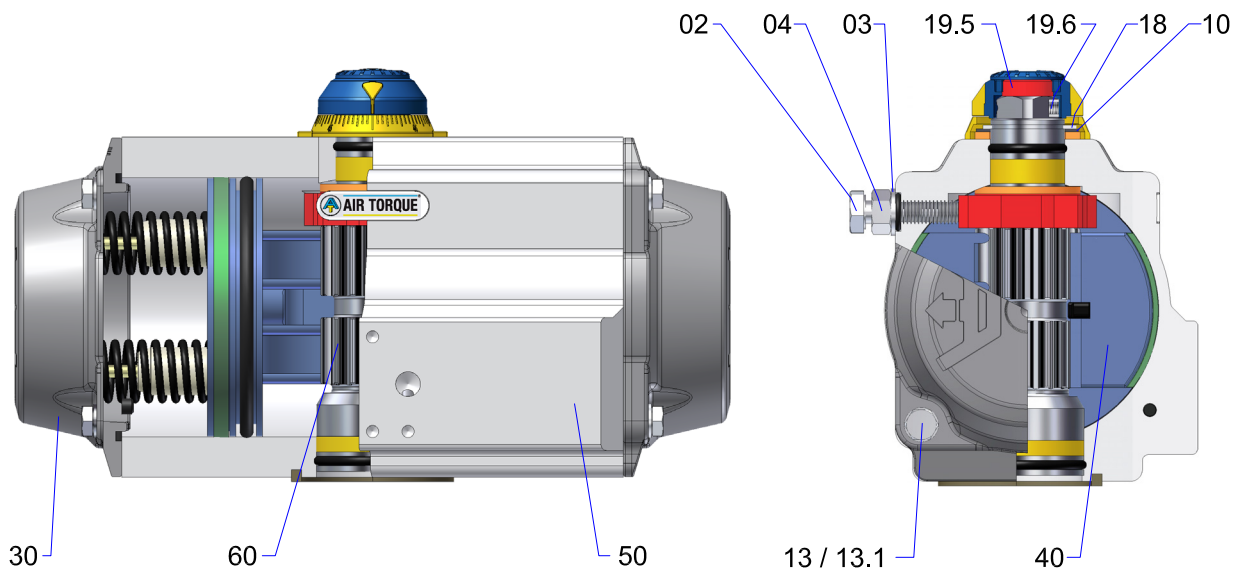

PART N°	UNIT Q.TY / NOTE	PART DESCRIPTION	STANDARD MATERIAL	CORROSION PROTECTION	COATING THICKNESS IN µ	STANDARD COLOUR
02	2 NA for AT045U	STOP CAP SCREW	Stainless Steel A2 70 (ISO3506)	/	/	/
03	2 NA for AT045U	WASHER	Stainless Steel A2 70 (ISO3506)	/	/	/
04	2 NA for AT045U	NUT (Stop screw)	Stainless Steel A2 70 (ISO3506)	/	/	/
10	1 for AT045U ÷ AT1001U	THRUST WASHER (Pinion)	Stainless Steel AISI 304	/	/	/
13	8/12/16 for AT045U ÷ AT801U	CAP SCREW (End cap)	Stainless Steel A2 70 (ISO3506)	/	/	/
13.1	16 only for AT1001U	WASHER (Cap Screw end cap)	Stainless Steel A2 70 (ISO3506)	/	/	/
18	1 for AT045U ÷ AT1001U	SPRING CLIP (Pinion)	Spring Steel	E.N.P.	/	/
19.5	1 NA for AT045U ÷ AT101U	TOP ADAPTOR	Extruded Aluminium alloy	Anodized	45 - 50	/
19.6	2 NA for AT045U ÷ AT101U	HEX SOCKET SCREW (Top Adaptor)	Stainless Steel A2 70 (ISO3506)	/	/	/
30	2 for AT045U ÷ AT801U only for AT1001U	END CAP	Pressure Die Cast Aluminium alloy Cast Aluminium alloy	Anodized	15 - 20	Dark Grey
40	2 for AT045U ÷ AT801U only for AT1001U	PISTON	Pressure Die Cast Aluminium alloy Cast Aluminium alloy	Anodized	10 - 15	Black
50	1 for AT045U ÷ AT751U for AT801U and AT1001U	BODY	Extruded Aluminium alloy Cast Aluminium alloy	Anodized Anodized	20 - 30 15 - 20	Bright Stainless Steel Dark Grey
60	1 for AT051U ÷ AT801U for AT045U and AT1001U	DRIVE SHAFT	Steel Extruded Aluminium alloy	E.N.P. Anodized	20 - 25 25 - 30	/ /

Note:

- For all other parts description and material see technical data sheet of the proper model.